

# MiniStrip Precision Stripping Tool

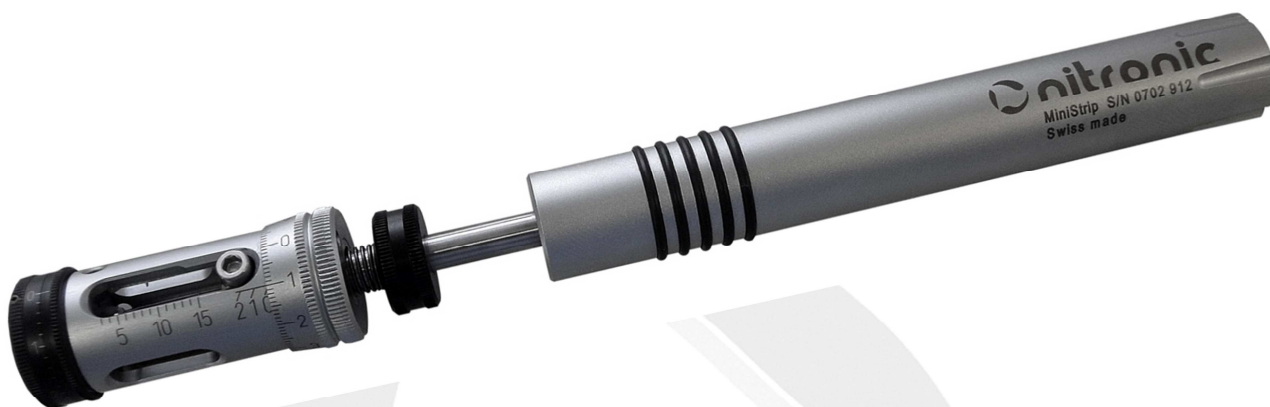

## Operating Instructions

Edition V2/10

Please read through these Operating Instructions carefully before starting work.

## General

Thank you for your custom and for choosing to purchase this tool from us.

Please read this operating instructions thoroughly in order to ensure the best possible performance from the tool. The warranty does not extend to damage caused by non-observance of the instructions. We are not liable for any consequential loss.

## Symbols

The following symbols draw your attention to the various danger warning levels indicated in each chapter:

 Please adhere strictly to the work practices and procedures indicated in this pictogram. Non-adherence could cause damage to the tool or the cable.

 This pictogram serves to illustrate work and operating procedures which must be adhered to, as well as to give important information about how the tool works.

## Table of Contents

General .....	2
Symbols .....	2
Table of Contents.....	2
Product description.....	3
Controls .....	3
Operation.....	4
Adjusting the centering diameter .....	4
Adjusting the stripping diameter.....	4
Adjusting the stripping length.....	5
Stripping operation .....	5
Adjusting the stripping length with a cable .....	6
Maintenance .....	7
Lubrication.....	7
Cleaning.....	7
Changing the stripping blades (without centering unit).....	7
Changing the stripping blades (with centering unit).....	9
Calibrating the centering device.....	12
Fault causes.....	13
Cable faults.....	13
Operational faults .....	13
Tool faults .....	13
Technical Data .....	14
Basic equipment.....	14
Standard MiniStrip with HSS blades .....	14
MiniStrip with Titanium coated carbide blades and centering unit.....	15
Replacement parts .....	15
Optional parts.....	15

## Product description

The all new cable stripping tool **Nitronic MiniStrip** was specially developed for thin cables. It features a patented four-blade system, which provides accurate and exactly repeated stripping of cables.

The coating is removed by cutting with rotating blades and strip-off in one single step. This simple procedure allows processing fiberoptic cables as well as coax and Teflon coated cables. The high precision avoids damage to wires or fibers.

Precision blade diameter control with a micrometer scale, allows a quick set-up of diameter. The locking screw of the diameter adjusting system makes the tool available even for military applications (mil-spec). The high quality of the product guaranties a precise repetitiveness.

Brief overview:

- Rotating cut
- Stripping head with 4 blades on one plane
- Blades replaceable by user without tools
- Fast and easy change of length and diameter
- mobile, no need for power supply



The **Nitronic MiniStrip** is exclusively designed to strip copper conductors. Please keep all metal objects (e.g. screwdriver, tweezers) away from the blades otherwise these will be damaged.

## Controls

1. Grip
2. Length setting ring
3. Stopper
4. Diameter setting
5. Stripping head
16. Locking screw (white)
17. Centering scale

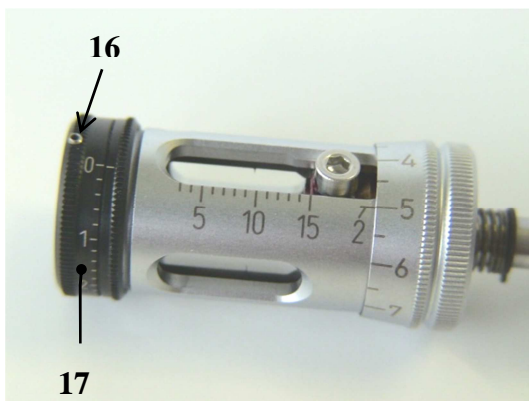
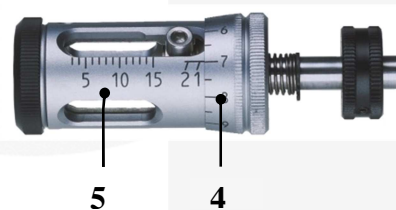

## Operation

### *Adjusting the centering diameter*

- First measure the outer diameter of the cable with the slide gauge.
- Then set a somewhat larger value on the centering scale **(17)** (**approx. + 0.05 mm**). The divisions of the centering scale are **0.2 mm**.

 The centering diameter should be set as accurately as possible. The stripping result would otherwise be unsatisfactory.

 Blocking of the centering device with the blocking screw **(16)** (**white**) is not absolutely necessary.

### *Adjusting the stripping diameter*

- First measure the diameter of the cable with the slide gauge.
- Then adjust the diameter setting **(4)** to a slightly larger diameter (**approx. + 0.1 mm**). The diameter setting increments are **0.01 mm**. (**Fig. 2**)

 The stripping diameter should be adjusted as accurately as possible. Otherwise the stripping result will be insufficient or the blades will be damaged.



Fig 2 Diameter Setting

## Adjusting the stripping length

- Release the length setting ring gauge (2) by twisting it in the direction of the arrow. (Fig. 3)
- Move the length setting ring gauge (2) and adjust the stopper (3) to the desired length using the setting. The setting increments are 1 mm per bar. (Fig. 3)
- Fix the length setting ring gauge (2) in position by twisting it in the opposite direction. (Fig. 3)

In case of diameters (<math><0.5\text{ mm}</math>) which are to be stripped very short (3 mm), the length setting ring gauge (2) should not be fixed in place, so that when the stripping head (5) is pulled back, the stripping blades can be opened fully (cleaning effect) (Fig. 4)

i

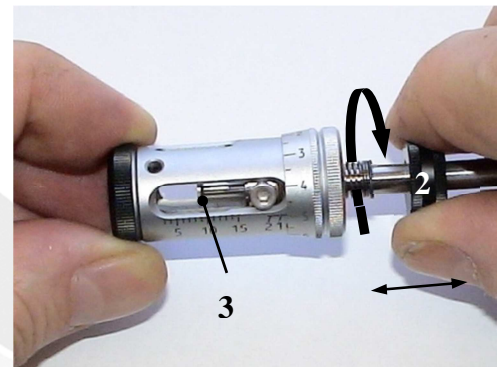

Fig. 3 Length setting

## Stripping operation

- Pull the stripping head (5) backwards up to the stopper. The four stripping blades are now fully open. (Fig. 4)
- Insert the cable horizontally through the head opening, until the end of the cable is touching the stopper (3). (Fig. 5)

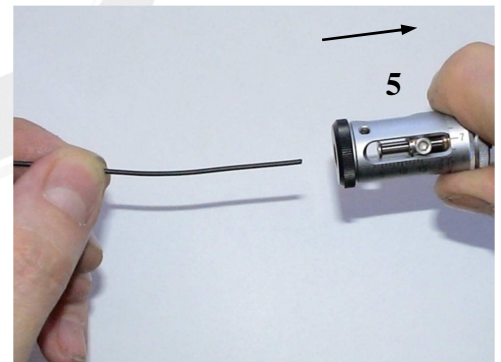

Fig. 4 Opening the blades

i

In order to ensure that the stripping lengths are as accurate as possible, the cable must not be put under too much tension.

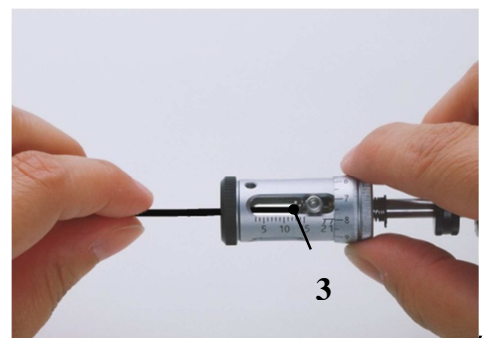

Fig 5. Insert the cable

- Slowly release the stripping head (5). The blades will close up to the outer diameter of the cable. (Fig. 6)
- Start the stripping action by pulling the grip and the cable, applying a consistent and constant pull. (Fig. 7)



This action will cause the stripping head to start turning and the blades will cut through the insulation until they reach the diameter which has been set. The constant pull between the grip and the cable then causes the insulation to be stripped from the wire. (Fig. 7)



If the stripping diameter is set too small, the blades will cut into the conductor and the insulation can then only be stripped off by pulling harder. This can damage the blades

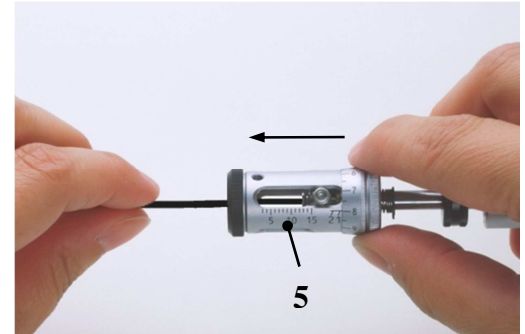

Fig. 6 Close the blades

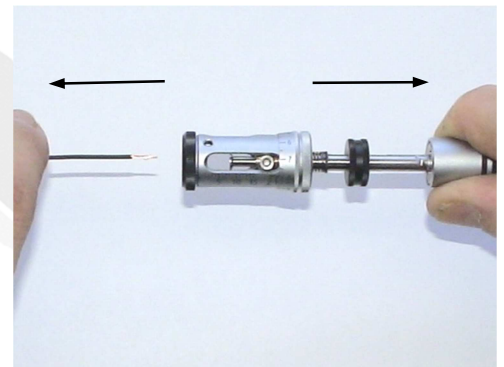

Fig. 7 Stripping

- Check that the wire has been stripped with a clean cut and at the correct length. Check and adjust the stripping diameter and stripping length as necessary.

### ***Adjusting the stripping length with a cable***



This procedure is only necessary in cases where the accuracy of the stripping length is particularly important.

- Adjust the diameter.
- Release the length setting ring gauge (2) by twisting it in the direction of the arrow, pull it as far back as it will go and fix into position. (Fig. 9)
- Pull the stripping head (5) backwards and insert the cable up to the desired length using the scale. Holding this position, slowly release the stripping head (5). (Fig. 8).

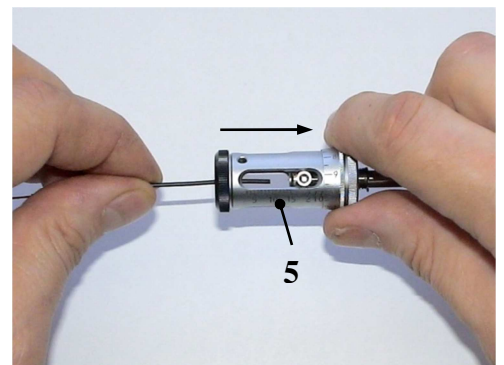

Fig. 8 Insert wire to desired length

- Release the length setting ring gauge again **(2)** by twisting it in the direction of the arrow, and push forwards until the stopper **(3)** is touching the cable. Then fix the length setting ring gauge **(2)** into position by twisting it in the opposite direction **(Fig. 9)**.
- Strip the cable and check the stripping length. Repeat the process if necessary.

The stripping length is now set and the **Nitronic MiniStrip** is ready for further stripping at the same stripping length.

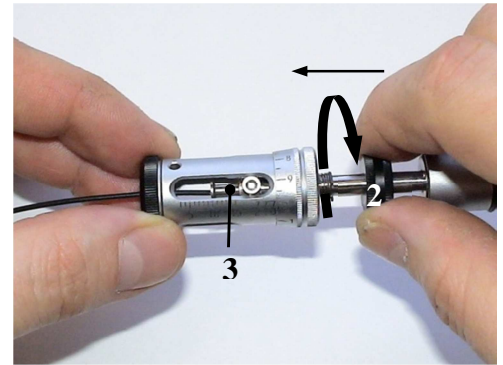

Fig. 9 Stopper setting

## Maintenance

The only maintenance required is cleaning of the stripping head.

### Lubrication

- ⚠ The **Nitronic MiniStrip** is designed in such a way that it does not require the application of grease or oil. In order to ensure correct function and long service life, avoid contaminating the tool with greasy or oily substances.

### Cleaning

The waste created by the stripping should be removed after each stripping to avoid placing any unnecessary stress on the stripping blades.

- After stripping, briefly pull the stripping head backwards; this causes the stripping blade to effectively clean away the waste.
- Clean the surface of the stripping head using a dry, clean brush only.
- Dirt on the grip, the spindle or the stripping head can be removed using a cloth dampened with kerosene.

### Changing the stripping blades (without centering unit)

- ⚠ The stripping blades must only be inspected and replaced by a suitably trained person.

- Set the diameter setting **(4)** to **1 mm**. **(Fig. 10)**



Fig. 10 Diameter setting

- Unscrew the end cap (6) and carefully pull out the cover plate (7). The four stripping blades (8) will now be visible. (Fig. 11)

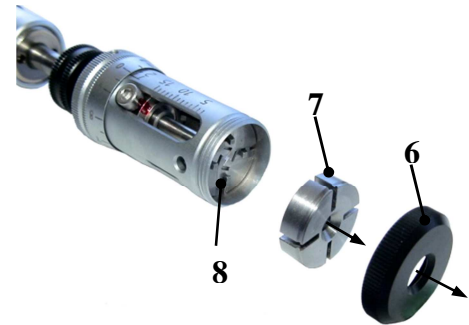

**i** In order to avoid losing the very small stripping blades, we recommend that you put down a dark-colored smooth mat and use a pair of tweezers. All four stripping blades must be changed at the same time in order to maintain a consistent stripping quality

Fig. 11 Removing cap and cover

- Remove each stripping blade (8) individually from the guide plate (9).
- If necessary, carefully clean the guide plate (9) with a dry brush
- Insert new stripping blades (8) individually. As far as possible, align the stripping blades with the track so that the blades do not subsequently jam. (Fig. 13)

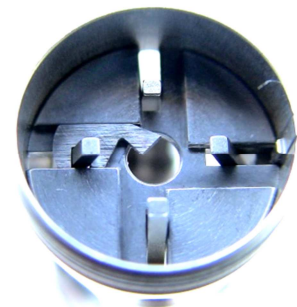
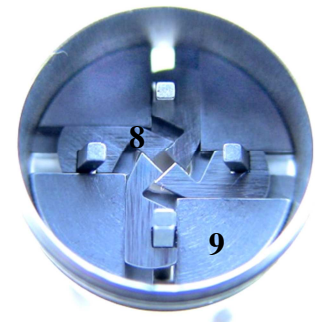

Fig. 13. Insert blades

- Carefully replace the cover plate (7). The chamfer (10) must point towards the outside. (Fig. 14)
- Screw the end cap (6) back on again, but **do not tighten**. (Fig. 14)

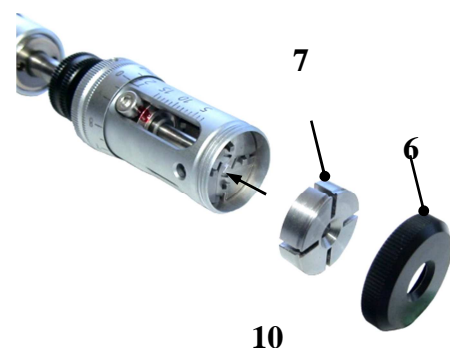



Fig. 14 Assemble plate and cover



- Set the diameter setting **(4)** to a diameter of **0 mm**.
- Slowly push the stripping head **(5)** back and forth. **(Fig. 15)**

 This will cause the four stripping blades to automatically settle into the tracks on the guide plate.

- Pull the stripping head **(5)** backwards as far as it will go and, holding this position, tighten the end cap **(6)**. **(Fig. 15)**

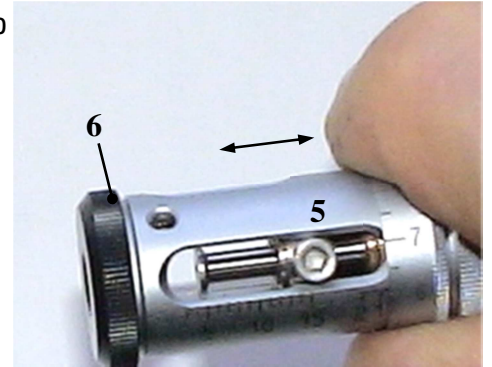

Fig. 15 Settle blades

The **Nitronic MiniStrip** is now ready for use.

### ***Changing the stripping blades (with centering unit)***

 The stripping blades must only be inspected and replaced by a suitably trained person.

- Set the diameter setting **(4)** to **1.5 mm**. **(Fig. 10)**

 In order to avoid losing the very small stripping blades, we recommend that you put down a dark-colored smooth mat and use a pair of tweezers. All four stripping blades must be changed at the same time in order to maintain a consistent stripping quality



Fig. 16. Diameter Setting

- Loosen screw **(19) (black)**, not the white one **(16)**!
- Loosen nut **(18)** and centering scale **(17)** together. **(Fig. 17)**

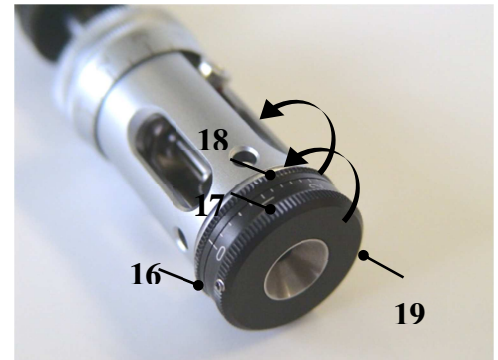

Fig. 17 Loosen centering unit

- The centering device can now be removed as a complete module. **(Fig. 18)**

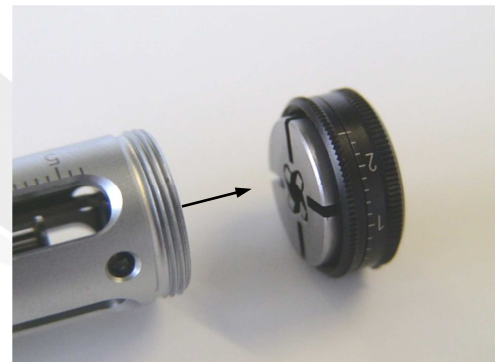
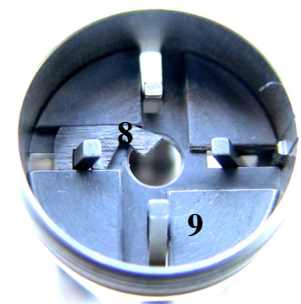

Fig.18 Remove centering device

- Remove each stripping blade **(8)** individually from the guide plate **(9)**.
- If necessary, carefully clean the guide plate **(9)** with a dry brush
- Insert new stripping blades **(8)** individually. As far as possible, align the stripping blades with the track so that the blades do not subsequently jam.



- Position and place down the centering device. (Fig. 20)



Fig. 20 Position centering device

- Screw in centering scale (17) together with the nut (18) as far as the stop, but do not yet tighten it. (Fig. 21)
- Set diameter scale (4) to a diameter of 0 mm .



Fig. 2 Screw in nut and centering scale

- Slowly push the stripping head (5) back and forth. (Fig. 22)

 This will cause the four stripping blades to automatically fit into the tracks on the guide plate



Fig. 22 Aligning the blades

- Pull the stripping head (5) backwards as far as will go and, holding this position, tighten the nut (18). (Fig. 22)

The centering device must now be calibrated in the next operating step.

## Calibrating the centering device

- Set diameter scale (4) to a diameter of 0 mm . (Fig. 23)



Fig. 23 Set diameter

- By rotating the centering scale (17), fully open the centering jaws (25) and insert calibrating pin (30). Then by rotating the centering scale (17) close the centering jaws as far as the calibrating pin (30). (Fig. 24)
- Loosen screw (19) (black) and set centering scale (17) to diameter 2 mm. Retighten screw (19) (black) and remove calibrating pin (30). (Fig. 24)



Fig. 24 Insert calibrating mandrel

The **Nitronic MiniStrip** is now ready for use.

## Fault causes

### *Cable faults*

Fault	Diagnosis	Remedy
Conductor, shielding or dielectric is cut	Cable highly eccentric	Incrementally increase the stripping diameter
Isolation does not strip off	Diameter differential between isolation and wire is very small.	Gradually reduce the stripping diameter.

### *Operational faults*

Fault	Diagnosis	Remedy
Isolation is not stripped off	Pull between grip and cable is too strong or too weak.	Apply consistent and constant pull during stripping.
Isolation does not strip off	Diameter differential between isolation and wire is very small.	Optimize the stripping diameter.

### *Tool faults*

Fault	Diagnosis	Remedy
Cable will not feed in. Wire has been cut into.	Stripping waste in the stripping head.	Clean by pulling back and releasing the stripping head several times.
Poor stripping quality	Stripping blades broken or worn.	Change the stripping blades
Stripping head will not go back into the starting position.	Spindle is dirty	Clean the spindle
Stripping head can no longer be pulled backwards.	Guide plate is dirty.	Remove stripping waste with brush.

## Technical Data

Processable wire diameter	0.25-1.5mm (AWG 30-15)
Depending on type of insulation possible	up to 0.16mm (AWG 34)
Outer cable diameter	up to 2.5mm
Stripping length	up to 15mm
Diameter setting	Increments 0.01mm
Stripping length setting	Increments 1mm
Stripping system	Rotational cutting action with four blades set at the same level.
Dimensions	Diameter 18mm Length 165mm
Weight	90g
Construction	entirely metal construction
Stripping blades	HSS, (Titanium coated carbide optional)
Processable insulation materials	PVC, Teflon, Kapton, Tefcel, Kynar etc.
Blade change	no tools needed

**Subject to technical modification without prior notice.**

## Basic equipment

*Standard MiniStrip with HSS blades*

Quantity	Description	Article Number
1	MiniStrip	010065
1	Protective cover	EN-7210
1	Operating instructions	EN-7110
1	Or short instructions and CD-ROM	
1	Headless blocking screw	
1	Allen Key	

### *MiniStrip with Titanium coated carbide blades and centering unit*

Quantity	Description	Article Number
1	MiniStrip	010070
1	Protective cover	EN-7210
1	Operating instructions	EN-7110
1	Or short operating instructions and CD-ROM	
1	Headless blocking screw	
1	Allen Key	
1	Allen Key	
1	Calibrating mandrel	

### Replacement parts

Quantity	Description	Article Number
1 Set	Stripping blades HSS (4 pcs.)	010075
1Set	Stripping blades, Titanium coated carbide (4 pcs.)	010079
1	O-Ring	010215
1	Sealing cap	010216
1	Blade cover plate	010201
1	Guide plate	010225
1	End cap	010200

### Optional parts

Quantity	Description	Article Number
1	Bench clamp	010080
1	Centering unit	010199
1	Case for MiniStrip	010086
1	Anti-roll	010089
1	Tweezers	010088