

Ac ILF 300/600

Accessories

The BOFA inline pre filters have been designed specifically for applications that generate high amounts of dust or particulate.

The filter unit is positioned alongside the main BOFA fume filtration system to increase the overall filter capacity and extend the life of the main filters.

A range of application dependent filter types and configurations are available on request.

STANDARD FEATURES:

- Extended filter life
- Large filtration area
- Choice of F6 bag or F8 pocket filters

Inline Filtration System



Laser Process

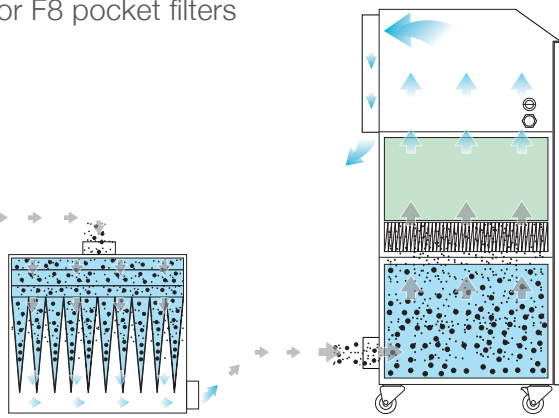

Inline filter

Filtration system

Inline filter delivering a longer life for applications that generate high amounts of dust and particulate.



Inline Filter (ILF) 600

Inline Filter (ILF) 300

UNIT PART NUMBERS		REPLACEMENT FILTER PART NUMBERS	
Model	Part No.	F6 Pre Filter	F8 Pre Filter
ILF 300 with a 5 pocket F6 filter. Stainless Steel	A1030069	A1030132 (5 Pocket)	A1030290 (5 Pocket)
ILF 600 with a 10 pocket F6 filter. Stainless Steel	A1030073	A1030151 (10 Pocket)	A1030255 (10 Pocket)

TECHNICAL DATA - INLINE FILTER 300		
	230V	115V
Dimensions (HxWxD)	753 x 630 x 310 mm	29.6 x 26.7 x 12.2"
Cabinet Construction	Stainless Steel	Stainless Steel
Weight	25kg	55lbs
Exhaust Outlet	125mm	4.9"

TECHNICAL DATA - INLINE FILTER 600		
	230V	115V
Dimensions (HxWxD)	753 x 630 x 610 mm	29.6 x 26.7 x 24"
Cabinet Construction	Stainless Steel	Stainless Steel
Weight	40kg	88lbs
Exhaust Outlet	125mm	4.9"

F6 PRE FILTER SPECIFICATIONS	
Filter Media Construction	Bag Filter
Filter Efficiency	F6 (82% @ 1 microns)

F8 PRE FILTER SPECIFICATIONS	
Filter Media Construction	Pleated Filter
Filter Efficiency	F8 (95% @ 0.9 microns)

AIRFLOW THROUGH FILTERS

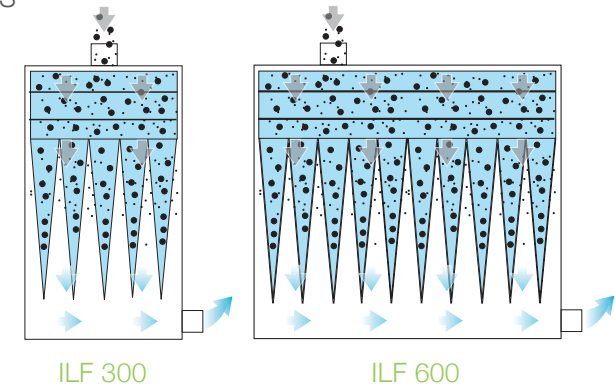
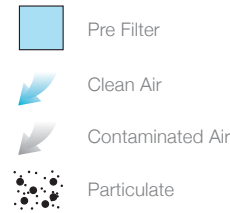

TECHNICAL SPECIFICATION

ILF 300

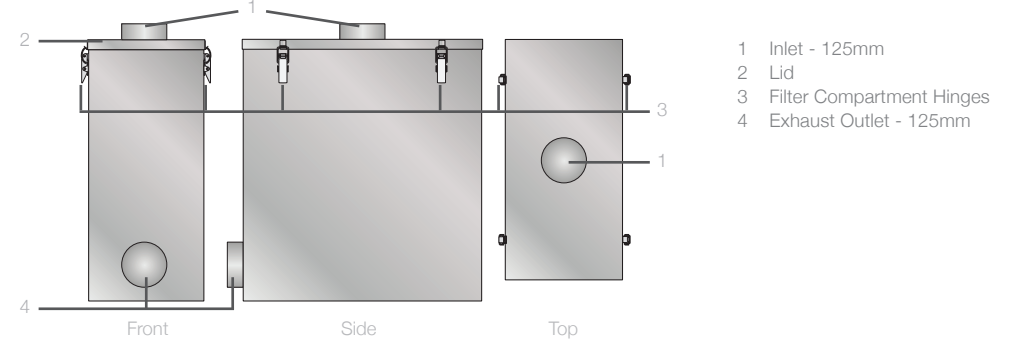

ILF 600

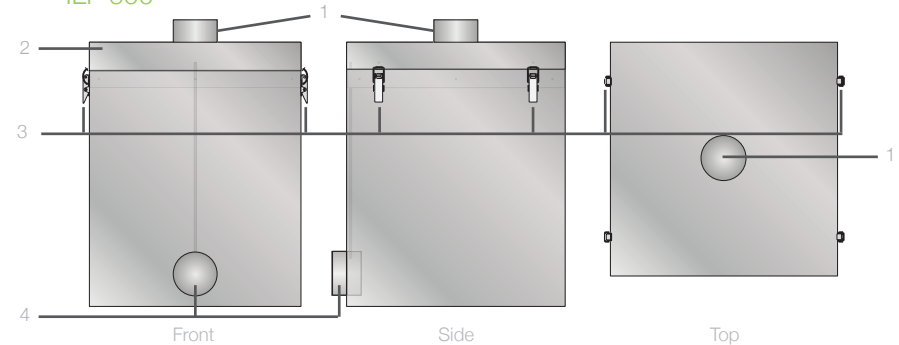

Other hose kits and filters are available. All of the above units are fitted with our standard filter combinations. For specific applications please call us for details. Replacement filters should always be ordered using the part number on the filters inside your extractor to ensure the correct filter is ordered. Datasheet correct at time of print.

Date:11/2/15 V:2.3

BOFA INTERNATIONAL LTD

Tel: +44 (0) 1202 699 444 Fax: +44 (0) 1202 699 446 Email: sales@bofa.co.uk Web: www.bofa.co.uk

BOFA AMERICAS, INC

Tel: (618) 205 5007 Fax: (866) 707 2632 Email: sales@bofaamericas.com Web: www.bofaamericas.com



British Quality

