

G1086 Coefficient of Friction Fixture - Assembly Instructions

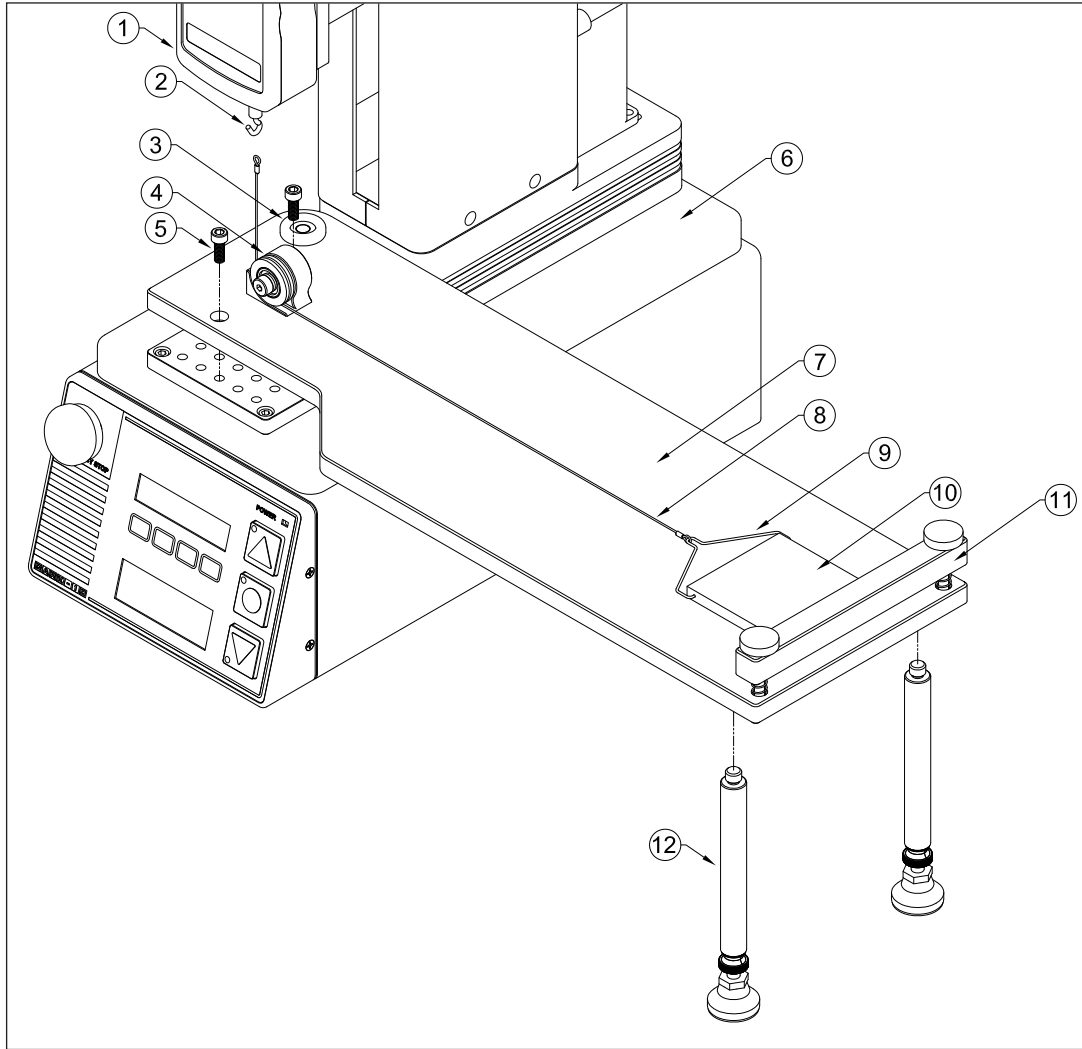

The G1086 COF fixture is designed for use with a Mark-10 ESM303, ESM301, or ESM301L motorized test stand and M5-2-COF digital COF gauge. The G1086 can be used for a wide range of materials, and conforms to ASTM D1894 and relevant standards. The illustration at left depicts proper assembly. Please follow these instructions:

1. Attach the COF gauge (1) to the test stand (6), then attach the hook (2) to the COF gauge load cell shaft (included with the gauge).
2. Fasten the threaded posts (12) to the underside of the work table (7). Each post consists of two pieces, to accommodate any of the above mentioned test stands.
3. Attach the work table to the test stand mounting plate utilizing two screws (5). Adjust the levelling feet at the end of the posts and monitor the level (3) to ensure the surface is horizontal.
4. Guide the rightmost cable loop (8) around one of the free ends of the wire hanger (9). Then attach the free ends to the sled (10) by spreading the two ends slightly and inserting into the holes in either side of the sled. Guide the other cable loop around the hook mounted to the COF gauge.
5. Secure base sample material to the workbench via the sample clamp (11), as required.
6. Wrap sample material around the sled, as required.
7. As the test stand crosshead moves upwards, the cable is pulled around the low-friction pulley (4) and drags the sled over the material. The static and kinetic coefficients of friction are recorded by the COF gauge. Detailed instructions for the Mark-10 COF gauge and motorized test stand may be found in their respective user's guides.