



THE WORLD LEADER IN  
FUME EXTRACTION TECHNOLOGY

## FC FumeCAB 700

Partial enclosures are becoming the recommended extraction option for a variety of applications. Government bodies, including the HSE in the UK are now making direct reference through guidance documentation such as the new HSG258 to their use.

The FumeCAB 700 integrated filtration system has been designed to ensure compliance with the latest regulations. The innovative Cam filter change design enables safe and simple front loading filter replacement and provides many benefits over alternative rear access systems.

Ultra-bright slim line energy saving LED lights come as standard with optional UV lighting, making the FumeCAB 700 an ideal choice for applications such as the conformal coating of PCBs, where operators can now easily identify uniformity issues with the coating.

### STANDARD CABINET FEATURES:

- Certified to BS 7989:2001 - Recirculatory filtration fume cabinet specification
- Ensures operational compliance with HSG258 guidelines
- Auto Sensing Flow Control
- Energy saving ultra-bright slim line LED lighting
- Twin coated anti UV / anti splash protective Polycarbonate visor
- Low noise level
- Large working area
- Side entry blind grommets for equipment access
- Audible and visual warning alarms

The complete solution for fume cabinet extraction for a broad range of applications

### TYPICAL APPLICATIONS:

- Soldering
- Conformal Coating
- Document Archiving
- Museum Works of Art Restoration
- Low volume spray painting / Varnishing
- Laboratory work
- Hobby / Craft industries
- Schools and Universities
- Asbestos testing

### OPTIONAL CABINET FEATURES:

- UV Lighting
- VOC monitor
- Stand



BOFA's safe and easy innovative front loading Cam filter replacement system.

UNIT PART NUMBERS						FILTER PART NUMBERS	
Model	Voltage	Part No.	Optional UV Lights	Optional VOC Monitor	Optional Stand	Pre Filter	Combined Filter
FumeCAB 700 Powder Coated	115V	E2741A	A2009	A2003	A1060063	A1030269	A1030270
	230V	E2742A					

TECHNICAL DATA		
	230V	115V
Dimensions (HxWxD)	780 x 680 x 490 mm	30.7 x 26.8 x 19.2"
Opening Dimensions (hxxw)	675 x 225mm	26 . 8.8"
Cabinet Construction	Powder coated mild steel	Powder coated mild steel
Face Velocity	0.4m/s	78.7ft/min
Max Face Velocity	0.6m/s	118ft/min
Electrical Data	230v 50/60Hz Full load current: 2 amps	115v 50/60Hz Full load current: 2 amps
Noise Level	< 53dBA*	< 53dBA*
Weight	65kg	143lbs
Exhaust Outlet (Optional)	100mm	

\* At typical operating speed.

PRE FILTER SPECIFICATIONS	
Filter Media Construction	Filter pad
Filter Housing	Cardboard
Filter Efficiency	H11 (99% @ 0.3 microns)

COMBINED FILTER SPECIFICATIONS	
HEPA Filter Media	Glass fibre
HEPA Media Construction	Maxi Pleat construction with webbing spacers
Filter Housing	Zintec mild steel
Treated Activated Carbon	10kgs
Filter Efficiency	H13 (99.997% @ 0.3 microns)

OPTIONAL STAND SPECIFICATIONS	
Dimensions (HxWxD)	1010 x 1090 x 740mm / 39.7 x 42.9 x 29.1"
Stand Construction	Powder coated mild steel

### INTERNAL WORK AREA

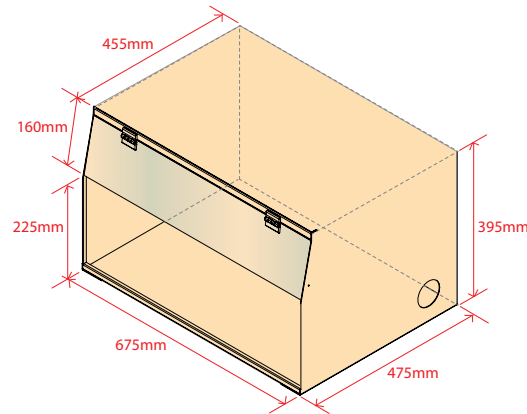

### AIRFLOW THROUGH FILTERS

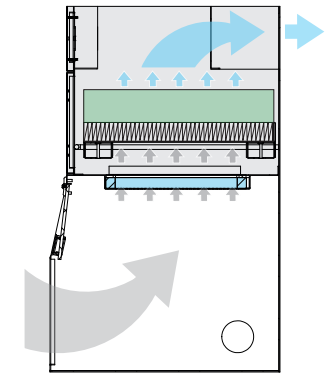
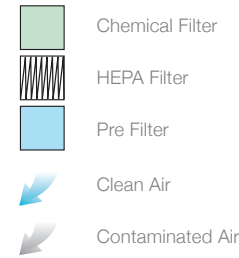

### TECHNICAL SPECIFICATION

- 1 Unit / Filter Condition Display - Automatic Flow Control
- 2 On / Off Switch
- 3 Filter Compartment Hinges
- 4 Cable Entry Grommet
- 5 Transparent Visor
- 6 Transparent Visor Hinges
- 7 Power cable Inlet
- 8 Internal LED Lighting
- 9 Exhaust Outlet
- 10 Optional Stand
- 11 Optional Stand Castors
- 12 LED/UV Light Switch

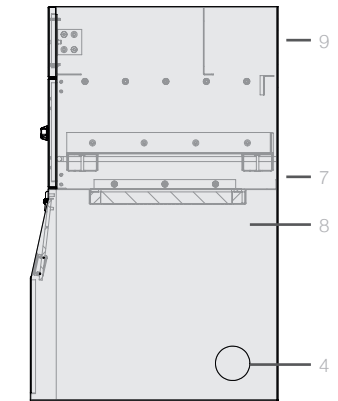

Left Side

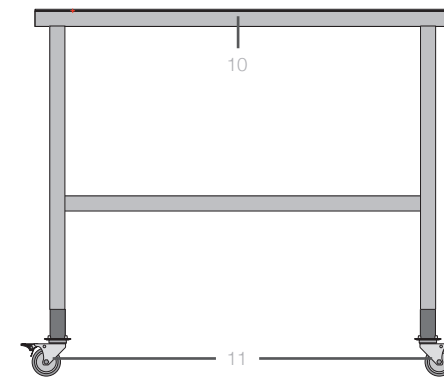

Optional Stand

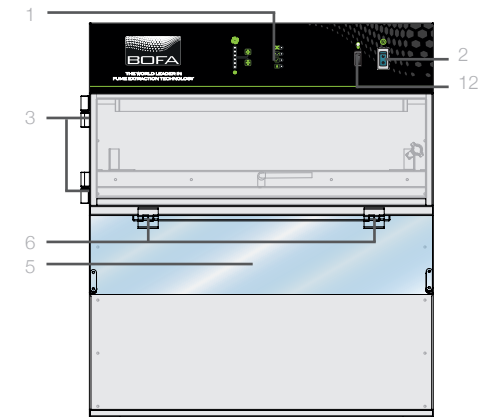

Front

Date:18/7/12 V:1.4

Other hose kits and filters are available. All of the above units are fitted with our standard filter combinations. For specific applications please call us for details. Replacement filters should always be ordered using the part number on the filters inside your extractor to ensure the correct filter is ordered. Datasheet correct at time of print.



#### BOFA INTERNATIONAL LTD

Tel: +44 (0) 1202 699 444 Fax: +44 (0) 1202 699 446 Email: sales@bofa.co.uk Web: www.bofa.co.uk

#### BOFA AMERICAS, INC

Tel: (618) 635 4465 Fax: (866) 707 2632 Email: sales@bofaamericas.com Web: www.bofaamericas.com

